

Technology and Livelihood Education

Quarter 1 - Module 3

Draft and cut pattern for ladies' skirt (Drafting the front and back pattern of a ladies' skirt)

Dressmaking NC II

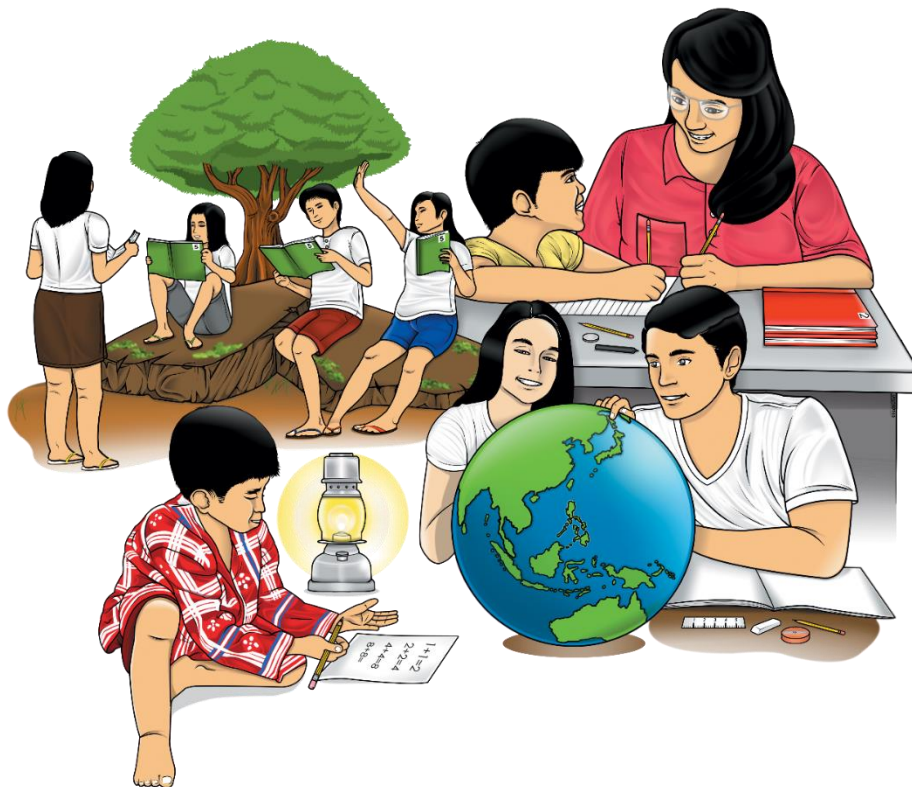

10

Technology and Livelihood Education

Quarter 1 - Module 3

Draft and cut pattern for ladies' skirt

(Drafting the front and back
pattern of a ladies' skirt)

Dressmaking NC II

Dressmaking – Grade 10

Quarter 1 – Module 3: Draft and cut pattern for ladies’ skirt (Drafting the front and back pattern of a ladies’ skirt)

Republic Act 8293, section 176 states that: No copyright shall subsist in any work of the Government of the Philippines. However, prior approval of the government agency or office wherein the work is created shall be necessary for exploitation of such work for profit. Such agency or office may, among other things, impose as a condition the payment of royalties.

Borrowed materials (i.e., songs, stories, poems, pictures, photos, brand names, trademarks, etc.) included in this module are owned by their respective copyright holders. Every effort has been exerted to locate and seek permission to use these materials from their respective copyright owners. The publisher and authors do not represent nor claim ownership over them.

Published by the Department of Education
Secretary: Leonor Magtolis Briones
Undersecretary: Diosdado M. San Antonio

Development Team of the Module

Writer: Romana T. Laoyan

Editors:

Reviewer: Jonalyn C. Ambrona
Mary Jane N. Malihod

Illustrator:

Layout Artist:

Management Team: Estela Leon-Cariño
Carmel F. Meris
Rosita C. Agnasi
Marie Carolyn B. Verano
Christopher C. Benigno
Juliet C. Sannad
Mary Jane N. Malihod
Armi Victoria Fiangaan
Brenda M. Cariño

Printed in the Philippines by:

Department of Education – Cordillera Administrative Region

Office Address: Wangal, La Trinidad, Benguet

Telefax: (074) -422 -4074

E-mail Address: car@deped.gov.ph

Introductory Message

This Self-Learning Module (SLM) is prepared so that you, our dear learners, can continue your studies and learn while at home. Activities, questions, directions, exercises, and discussions are carefully stated for you to understand each lesson.

Each SLMS is composed of different parts. Each part shall guide you step-by-step as you discover and understand the lesson prepared for you.

Pre-tests are provided to measure your prior knowledge on lessons in each SLM. This will tell you if you need to proceed on completing this module or if you need to ask your facilitator or your teacher's assistance for better understanding of the lesson. At the end of each module, you need to answer the post-test to self-check your learning. Answer keys are provided for each activity and test. We trust that you will be honest in using these.

In addition to the material in the main text, Notes to the Teacher are also provided to our facilitators and parents for strategies and reminders on how they can best help you on your home-based learning.

Please use this module with care. Do not put unnecessary marks on any part of this SLM. Use a separate sheet of paper in answering the exercises and test. And read the instructions carefully before performing each task.

If you have questions in using this SLM or any difficulty in answering the tasks in this module, do not hesitate to consult your teacher or facilitator.

Thank you.



Notes to the Teacher

This contains helpful tips or strategies that will help you in guiding the learner.

For the facilitator:











Hi, as a facilitator you are expected to orient the learners on how to use this module. You also need to keep track of the learners' progress while allowing them to manage their own learning. Kindly, advise the learner's parents or guardians of the same procedure since they will be the primary supporters in the learners' progress. Please, do not forget to remind the learner to use separate sheets in answering all of the activities found in the learning module.

For the learner:

Hello learner, Welcome to the Dressmaking NC II Alternative Delivery Mode (ADM) Module on drafting the front and back pattern of a ladies' skirt. I hope you are ready

to progress in your Grade 10 TLE in Dressmaking NC II with this learning module. This is designed to provide you with interactive tasks to further develop the desired learning competencies prescribed in our curriculum. With this, you are expected to appreciate staking through the information and activity given.

This module has the following parts and corresponding icons:

ICON	LABEL	DETAIL
	What I Need to Know	This contains the learning objectives which you need to accomplish.
	What I know	This evaluates what you know about the lesson you are to learn.
	What's In	This connects the current lesson with a topic necessary in your understanding.
	What's New	This introduces the lesson through an activity.
	What Is It	This contains a brief discussion of the learning module lesson.
	What's More	These are activities to check your understanding of the lesson.
	What I Have Learned	This summarizes the important ideas presented in the lesson.
	What I Can Do	This is a real-life application of what you have learned.
	Assessment	This is a post assessment of what you have learned.
	Additional Activity	This is an activity that will strengthen your knowledge about the lesson.

At the end of this module you will also find:

References

This is a list of all sources used in developing this module.

TABLE OF CONTENTS

What I Need to Know	Error! Bookmark not defined.
What I Know	2
What's In	3
What's New	4
What Is It.....	5
What's More	7
What I Have Learned	8
What I Can Do	9
Post - Assessment	13
Additional Activity	15
Answer Key	16
References	17

Lesson

1

Drafting the Front and Back pattern of a ladies skirt

The following are some reminders in using this module:

1. Use the module with care. Do not put unnecessary mark/s on any part of the module. Use a separate sheet of paper in answering the exercises.
2. Don't forget to answer *What I Know* before moving on to the other activities included in the module.
3. Read the instruction carefully before doing each task.
4. Observe honesty and integrity in doing the tasks and checking your answers.
5. Finish the task at hand before proceeding to the next.
6. Return this module to your teacher/facilitator once you are through with it.

If you encounter any difficulty in answering the tasks in this module, do not hesitate to consult your teacher or facilitator. Always bear in mind that you are not alone.

We hope that through this material, you will experience meaningful learning and gain deep understanding of the relevant competencies. You can do it!



What I Need to Know

This module was designed and written to guide you to acquire the learning competencies and develop your skills in taking a body measurement in dressmaking. The scope of this module permits it to be used in many different learning situations. The language used recognizes the diverse vocabulary level of students. The lessons are arranged to follow the standard sequence of the course. However, the order in which you read the module can be changed to correspond with the textbook you are now using.

Quarter/Week

Q1/W2

Learning Competency Code

TLE_HEDM9-12SK-Ia-c-1

Learning Competency

LO 1. Draft and cut pattern for ladies' skirt

1.3. Draft basic pattern of ladies skirt

Learning Objectives:

After going through this module, you are expected to:

1. identify the procedures in drafting the front and back pattern of ladies' skirt;
2. perform the procedures in drafting the front and back pattern of ladies' skirt; and
3. develop traits such as ingenuity, resourcefulness, creativity, independence and passion towards learning.



What I Know

Pretest

Multiple Choice.

Directions: Choose the letter of the best answer. Write the chosen letter on the answersheet.

- ____ 1. It is a lower part of a dress/ gown or a separate outer garment that covers a person from the waist downwards for the waist.
A. blouse B. pant C. skirt D. jacket
- ____ 2. What is the measurement of point A to N in drafting the dart pattern of A-line skirt?
A. $\frac{3}{4}$ of apex distance B. $\frac{1}{4}$ of apex distance
C. $\frac{1}{2}$ of apex distance D. $\frac{1}{8}$ of apex distance
- ____ 3. Which of the body measurement is used from point A to E in drafting The front pattern of A-line skirt?
A. $\frac{1}{2}$ of waist measure plus 1 inch
B. $\frac{1}{4}$ of waist measure plus 1 inch
C. $\frac{1}{3}$ of waist measure plus 1 inch
D. $\frac{3}{4}$ of waist measure plus 1 inch
- ____ 4. The procedures of A-line skirt, length is usually minus $1\frac{1}{2}$ inches because of _____?
A. hem B. waist band C. facing D. interfacing
- ____ 5. Which of the following body measurement is needed in making a dart skirt?
A. hip depth B. waist measure
C. apex distance D. apex height
- ____ 6. The front pattern of skirt is longer than the back part with at least .
A. 2 inches B. 1 inch C. $\frac{1}{2}$ inch D. $\frac{1}{4}$ inch
- ____ 7. Liza has a hip measure of 35 inches she need to get the $\frac{1}{4}$ of it, for pattern drafting of skirt, what is the $\frac{1}{4}$ of her hip measure?
A. $8\frac{1}{4}$ inches B. $8\frac{3}{4}$ inches C. $8\frac{1}{2}$ inches D. 8 inches
- ____ 8. What is the part of the skirt which is usually attached to the waistline?
A. band B. placket C. pocket D. fastener
- ____ 9. It is a skirt that is fitted at the hips and gradually widens toward the hem, giving the impression of the shape of a capital letter A.
A. balloon skirt B. A - line skirt
C. pencil cut skirt D. pleated skirt
- ____ 10. In drafting pattern of skirt, measurement used from point A to B is _____?
A. apex height B. hip depth C. waist measure D. hip measure

- ____ 11. How many parts must the waist measurement be divided?
 A. $\frac{1}{8}$ of waist measure B. $\frac{1}{2}$ of waist measure
 C. $\frac{1}{4}$ of waist measure D. $\frac{3}{4}$ of waist measure
- ____ 12. Which measurement is used from point A to point C, in drafting a pattern of A-line skirt?
 A. blouse length B. skirt length C. pant length D. Dress length
- ____ 13. Which among the items below is used by a dressmaker as a guide in cutting the fabric?
 A. tailor`s chalk B. pattern C. cutting shear D. pins
- ____ 14. In drafting a pattern of A-line skirt, the measurement from point C to D is _____?
 A. $\frac{1}{4}$ of bottom circumference B. $\frac{1}{8}$ of bottom circumference
 C. $\frac{1}{2}$ of bottom circumference D. $\frac{3}{4}$ of bottom circumference
- ____ 15. The measurement from point B to point F is hip measure, into how many part must be divided ?
 A. one half B. one eight C. one fourth D. one third



What's In

Activity 1: Clothing word search, find and underline the 20 words then, write your answer in the answer sheet.

CLOTHING word search

S	X	T	C	M	E	A	S	U	R	E	M	E	N	T
T	J	H	A	T	Y	T	E	A	X	Q	H	Z	W	Y
N	P	A	R	S	B	S	S	K	Z	S	O	B	J	R
A	Y	A	C	Q	R	H	S	F	W	H	P	W	G	L
P	E	C	T	K	P	I	E	J	A	D	Q	S	A	T
G	W	O	Q	T	E	R	R	Z	I	O	U	D	H	N
N	P	A	K	L	E	T	D	P	S	C	I	A	S	E
I	E	T	C	D	E	R	O	T	T	E	R	J	H	M
G	B	Z	J	S	B	L	N	B	S	L	K	Q	O	R
G	R	N	U	U	O	A	L	S	P	I	H	M	R	A
O	H	O	S	S	P	A	K	D	K	W	S	J	T	G
J	L	T	H	C	Z	I	M	X	Z	N	A	L	P	V
B	W	I	P	E	R	H	Y	C	O	K	J	M	A	W
L	R	J	R	T	X	R	A	E	W	R	E	D	N	U
T	H	S	S	Z	H	L	O	M	A	K	I	J	T	Q



What's New

In drafting a pattern for a certain garment, procedures should be follow step by step. Using the body measurement taken and to draft the basic skirt pattern use your own body measurement. This will then be the starting point for all kinds of skirt. And now we are going to learn the following in this lesson.

Let's Try This: Enumerate the measurement needed for A-line skirt which indicated by arrows then take your body measurement for pattern making.

Measurement Needed

- 1.
- 2.
- 3.
- 4.
- 5.
- 6.

BACK PATTERN

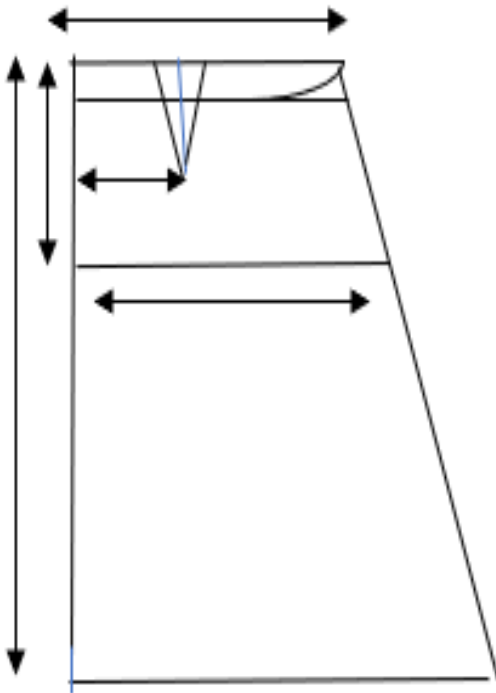

FRONT PATTERN

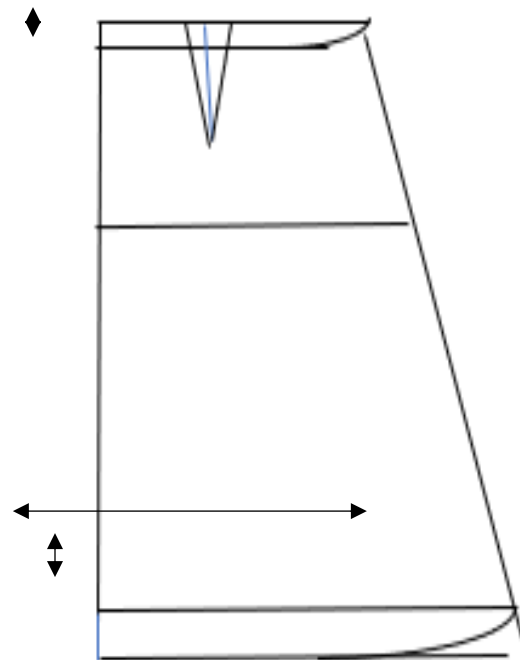



What Is It

How to Draft the front and back pattern of a ladies' skirt?

Measurement Needed:

1. Waist measure –
2. Hip measure –
3. Hip depth –
4. Skirt length –
5. Apex distance for the dart –
6. Bottom circumference –

Procedures: Front pattern

1. Construct vertical and horizontal line, then mark point A at the intersection line.
2. A to B- Hip depth (standard 7^{''}), then draw a horizontal line
3. A to C – skirt length minus 1 ½ inch for the waist band, then draw a horizontal line.
4. C to C1 - 1/2" downward, then a horizontal line
5. C to D – ½ of bottom circumference
6. A to E -1/4 of waist measure plus 1^{''}.
7. A to A1 – ½ inch downward.
8. B to F – ¼ of hip measure plus ½^{''}
9. Connect F to D with L -square.
10. Shape C1 to D with the use of hip curve.
11. Note. A1 to C should equal to E to D.

Dart

1. A to N – ½ of apex distance.
2. N to M – 3 ½^{''} or 4^{''}
3. N to O- ½^{''}
4. N to P – ½^{''}, then connect the point as illustrated.

Procedures : Back pattern

1. A to A1 – ¼^{''} downward, then draw a horizontal line
2. A to E – ¼ of waist measure plus 1
3. A to B- Hip depth (standard 7^{''}), then draw a horizontal line.
4. B to F – ¼ of hip measure plus ¼^{''}
5. A to C – skirt length downward, then draw a horizontal line
6. C to D – ½ of bottom circumference
7. Point A to C is equal to point E to D, then shape with hip curve.
8. Connect all points as illustrated in the drawing. Make a dart

DRAWING: FRONT PATTERN

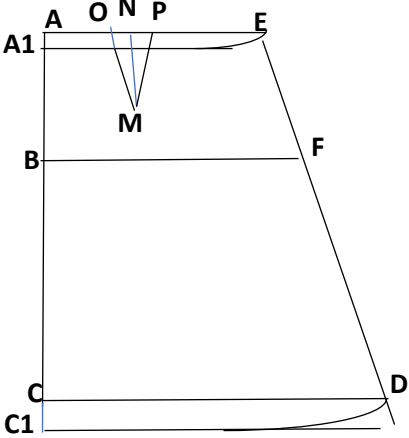

DRAWING: BACK PATTERN

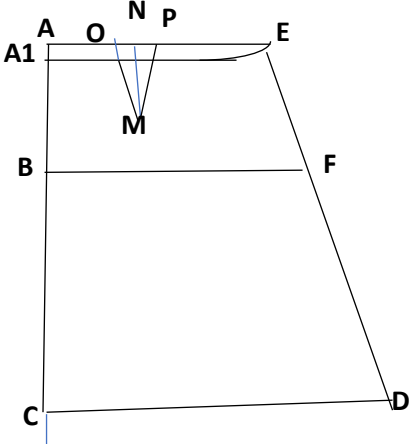



What's More

PERFECT PARTNERS

Activity 2. MATCHING TYPE:

Instruction: Match the measurement from column B to Column A, write your answer in the answer sheet.

COLUMN A Procedures	COLUMN B Measurement
1. A to C	a. 4 inches
2. A to A1	b. $\frac{1}{2}$ inch
3. N to P	c. $\frac{1}{2}$ of apex distance
4. C to C1	d. $\frac{1}{2}$ inch
5. A to B	e. $\frac{1}{4}$ of waist plus 1 inch
6. N to M	f. skirt length
7. A to N	g. $\frac{1}{4}$ of hip measure
8. C to D	h. $\frac{1}{2}$ inch
9. B to F	i. $\frac{1}{2}$ of bottom circumference
10. A to E	j. hip depth
	k. $\frac{1}{2}$ of hip measure

1. _____

8. _____

2. _____

9. _____

3. _____

10. _____

4. _____

5. _____

6. _____

7. _____



What I Have Learned

Activity 3. IDENTIFICATION

Instruction: Identify the body measurement used in the following illustrations represented by arrow. Write your answer in the answer sheet.

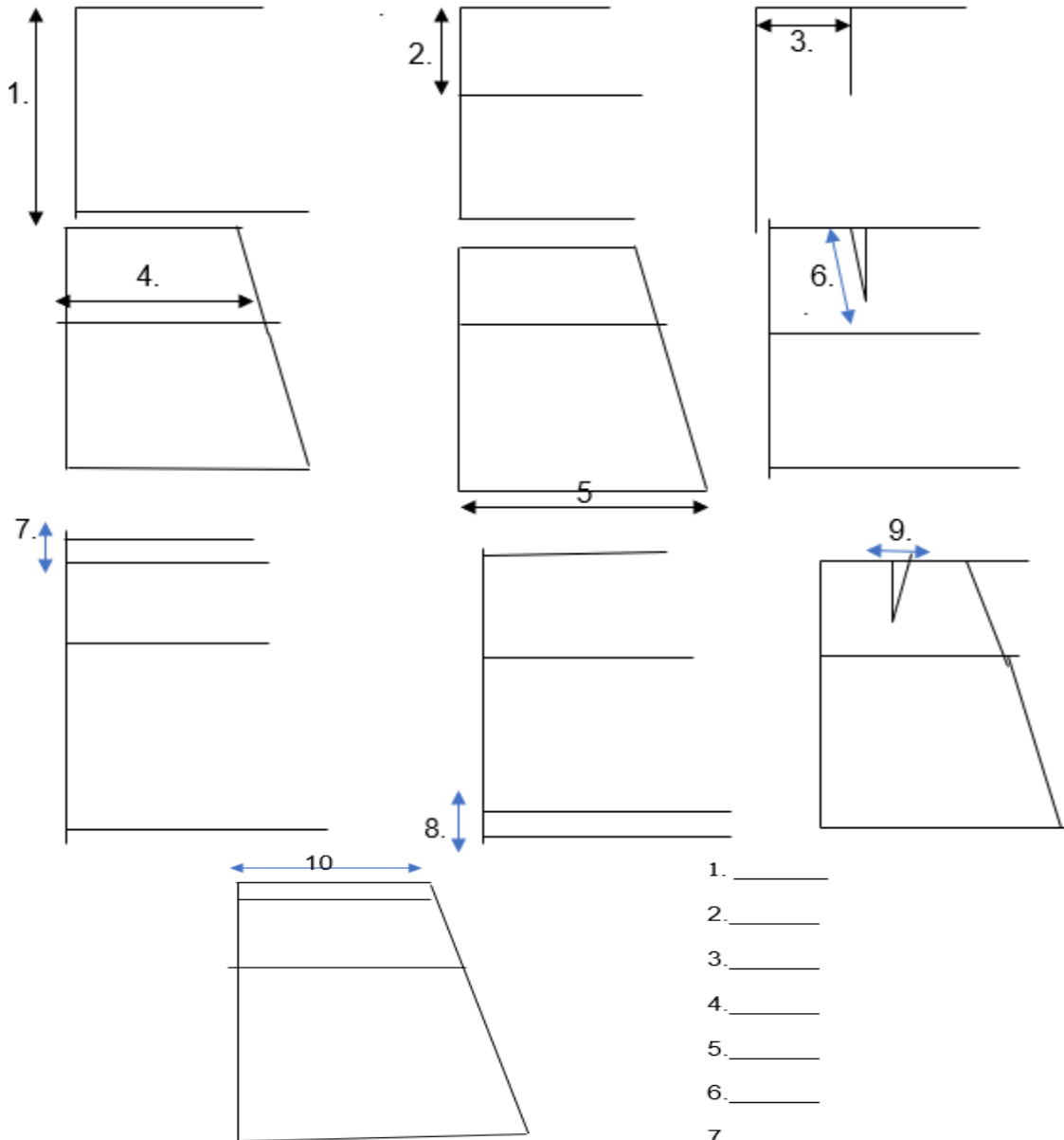

1. _____
2. _____
3. _____
4. _____
5. _____
6. _____
7. _____
8. _____
9. _____
10. _____



What I Can Do

Instruction: Start drafting the front pattern of A-line skirt using pattern paper, following the given procedures with the illustration below. Use your own body measurement.

FRONT PATTERN

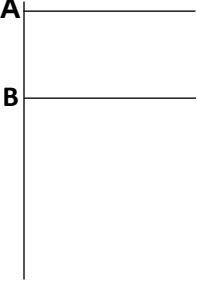
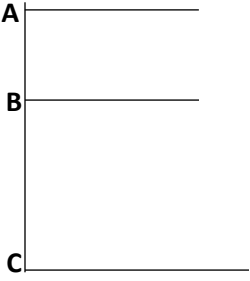
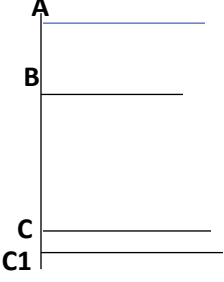
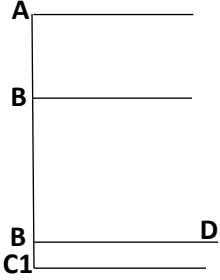
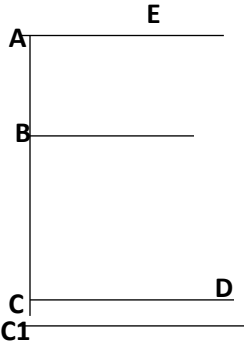
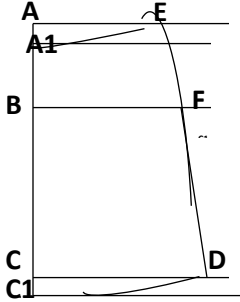
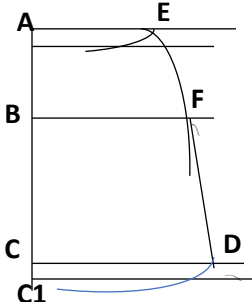
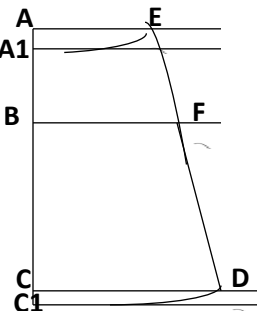
<p>1. Construct vertical and horizontal line, then mark point A at the intersection line.</p> 	<p>2. A to B- Hip depth (standard 7"), then draw a horizontal line</p> 	<p>3. A to C – skirt length minus 1 1/2 inch for the waist band, then draw a horizontal line.</p> 
<p>4. C to C1 - 1/2" downward, then a horizontal line</p> 	<p>5. C to D – 1/2 of bottom circumference</p> 	<p>6. A to E - 1/4 of waist measure plus 1".</p> 
<p>7. A to A1 – 1/2 inch downward</p> 	<p>8. B to F – 1/4 of hip measure plus 1/2"</p> 	<p>9. Connect F to D with L-square.</p> 

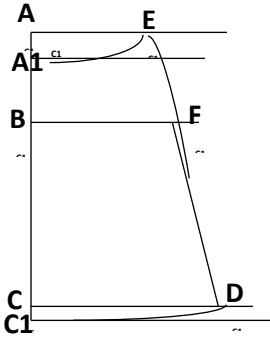
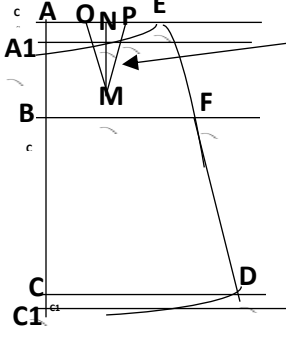
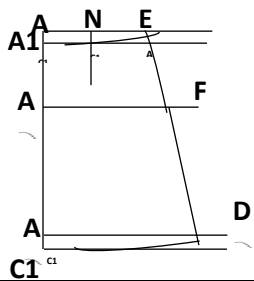
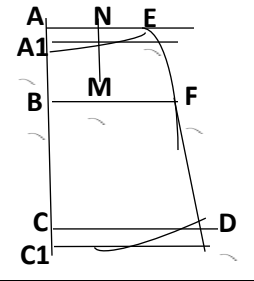
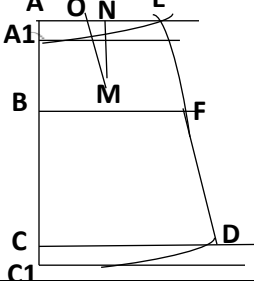
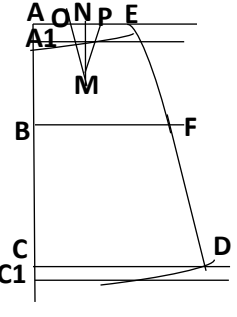
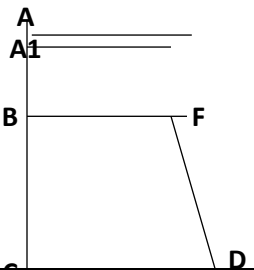
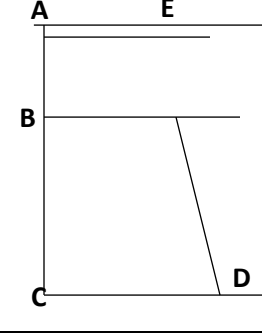
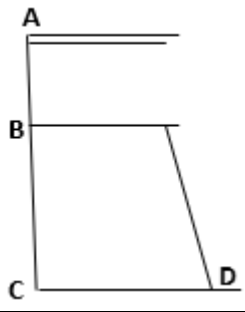
<p>10. Shape C1 to D with the use of hip curve.</p> 	<p>11. Note. A1 to C should equal to E to D</p> 	
DART		
<p>1. A to N - 1/2 of apex distance.</p> 	<p>2. N to M - 3 1/2" or 4"</p> 	<p>3. N to O - 1/2"</p> 
<p>4. N to P - 1/2", then connect the point as illustrated.</p> 		
<p>Back pattern: 1. A to A1 - 1/4" downward, then draw a horizontal line</p> 	<p>2. A to E - 1/4 of waist measure plus 1"</p> 	<p>3. A to B - Hip depth (standard 7"), then draw a horizontal line</p> 

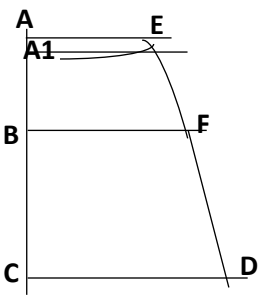
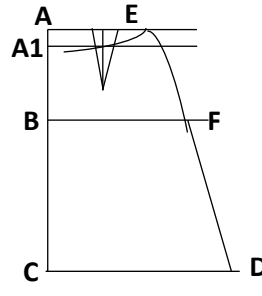
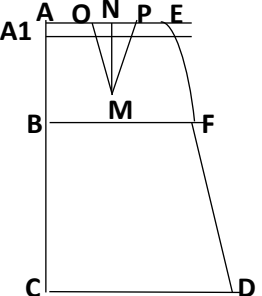
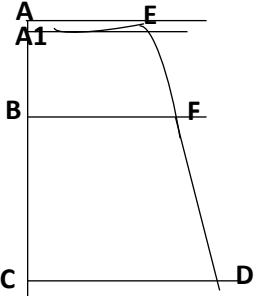
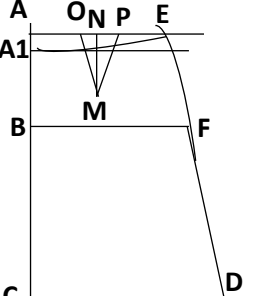
<p>4. B to F – $\frac{1}{4}$ of hip measure plus $\frac{1}{4}$''</p> 	<p>5. A to C – skirt length downward, then draw a horizontal line</p> 	<p>6. C to D – $\frac{1}{2}$ of bottom circumference</p> 
<p>7. Point A to C is equal to point E to D, then shape with hip curve.</p> 	<p>8. Connect all points as illustrated in the drawing. Make a dart</p> 	

CUT THE FINAL PATTERN with necessary allowances and pattern symbols

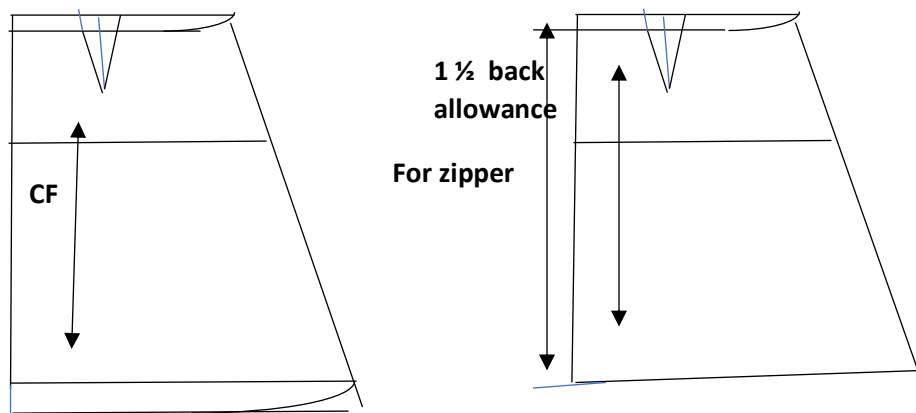

RUBRIC IN PATTERN DRAFTING FOR LADIES SKIRT

Criteria	50	30	15	Score
Use of drafting tools	Drafting tools were used correctly	Most of the drafting tools used correctly	Some of the drafting tools used correctly	
Workmanship	Procedures were followed correctly.	Most of the procedures were followed correctly	Some of the procedures were followed correctly	
Accuracy	Measurement were used accurately.	Most of the measurement were used accurately.	Some of the measurement were used accurately	
Neatness	Observed neatness of work.	There were less than 5 erasures in the pattern.	There were more than 5 erasures in the pattern.	
Speed	Finished ahead of time	Finished on time	Not finished on time	
			TOTAL	



Post-Assessment

Multiple Choice.

Directions: Choose the letter of the best answer. Write the chosen letter in an answersheet.

- ____ 1. What is a device used by dressmaker as a guide when cutting a fabric for garment?
A. tailor`s chalk B. patterns
C. cutting shear D. pins
- ____ 2. Which of the body measurement is used from point A to E in drafting the front pattern of A-line skirt
A. $\frac{1}{2}$ of waist measure plus 1 inch
B. $\frac{1}{4}$ of waist measure plus 1 inch
C. $\frac{1}{3}$ of waist measure plus 1-inch
D. $\frac{3}{4}$ of waist measure plus 1 inch
- ____ 3. The procedures of A – line skirt, length is usually minus $1 \frac{1}{2}$ inches because of?
A. hem B. waist band C. facing D. interfacing
- ____ 4. Which of the following body measurement is needed in making a dart for skirt?
A. hip depth B. hip measure C. apex distance D. apex point
- ____ 5. It is a lower part of a dress/ gown or a separate outer garment that covers a person from the waist downwards for the waist.
A. blouse B. pant C. skirt D. jacket
- ____ 6. What is the measurement of point A to N in drafting the dart pattern of A-line skirt?
A. $\frac{3}{4}$ of apex distance B. $\frac{1}{4}$ of apex distance
C. $\frac{1}{2}$ of apex distance D. $\frac{1}{8}$ of apex distance
- ____ 7. Liza has a hip measure of 35 inches. She need to get the $\frac{1}{4}$ of it for pattern drafting. What is the $\frac{1}{4}$ of her hip measure?
A. $8 \frac{1}{4}$ inches B. $8 \frac{3}{4}$ inches C. $8 \frac{1}{2}$ inches D. 8 inches
- ____ 8. What is that part of the skirt usually attached to the waistline ?
A. band B. placket C. pocket D. fastener
- ____ 9. Which measurement is used from point A to point C, in drafting a pattern of A-line skirt?
A. blouse length B. skirt length
C. pant length D. Dress length
- ____ 10. It is a skirt that is fitted at the hips and gradually widens toward the hem, giving the impression of the shape of a capital letter A.
A. balloon skirt B. A – line skirt
C. pencil cut skirt D. pleated skirt
- ____ 11. In drafting a pattern of A-line skirt, the measurement from point C

- to D is ?
- A. $\frac{1}{4}$ of bottom circumference B. $\frac{1}{8}$ of bottom circumferenc
C. $\frac{1}{2}$ of bottom circumference D. $\frac{3}{4}$ of bottom circumference
- ____ 12. The measurement from point B to point F is hip measure. How many part must be divided ?
A. one half B. one eight C. one fourth D. one third
- ____ 13. In drafting pattern of skirt, measurement used from point A to B is?
A. apex height B. hip depth C. waist measure D. Hip measure
- ____ 14. How many parts must the waist measurement be divided?
A. $\frac{1}{8}$ of waist measure B. $\frac{1}{2}$ of waist measure
C. $\frac{1}{4}$ of waist measure D. $\frac{3}{4}$ of waist measure
- ____ 15. The front pattern of skirt is longer than the back part with at least .
A. 2 inches B. 1 inch C. $\frac{1}{2}$ inch D. $\frac{1}{4}$ inch



Additional Activity

Picture Reading

Activity 4: IDENTIFICATION

Instruction: Identify the following types of skirt in the pictures. Select from the option given. Circular, A-line, Pleated, Box pleat, Pencil cut, Mini skirt, Godet, Peplum, Gather and Asymmetrical skirt.



1.



2.



3.



4.



5.



6.



7.



8.



9.



10



Answer Key

What I Know

1. c
2. b
3. b
4. b
5. c
6. c
7. c
8. a
9. b
10. b
11. c
12. b
13. b
14. c
15. c

What's New

1. waist measure
2. hip measure
3. skirt length
4. apex distance
5. bottom circumference
6. hip depth

What's More

1. f
2. b/h
3. d/h
4. h/b
5. j
6. a
7. i
8. h
9. g
10. c

What I Have Learned

1. skirt length
2. hip depth
3. 1/2 of apex distance
4. hip measure
5. bottom circumference
6. 3 1/2 or 4 inches
7. 1/2 inch
8. 1/2 inch
9. 1/2 inch
10. waist measure

What I Can Do

Performance output
will be evaluated
through given
rubrics

Post-Assessment

1. c
2. c
3. c
4. c
5. b
6. b
7. c
8. b
9. b
10. b
11. c
12. c
13. b
14. c
15. b

Additional Activity

1. Mini skirt
2. asymmetrical
3. godet
4. box pleat
5. peplum
6. pencil cut
7. pleated
8. A-line
9. gather
10. circular

References

Lewis, Dora. Clothing construction and Wardrobe planning. New York:
McMillan Publishing Company, 1955

Home Technology Clothing I and II. Garment Construction.

For inquiries or feedback, please write or call:

Department of Education - Bureau of Learning Resources (DepEd-BLR)
Ground Floor, Bonifacio Bldg., DepEd Complex
Meralco Avenue, Pasig City, Philippines 1600
Telefax: (632) 8634-1072; 8634-1054; 8631-4985
Email Address: blr.lrqad@deped.gov.ph * blr.lrp@deped.gov.ph
Telefax: (632) 8634-1072; 8634-1054; 8631-4985